

Centrifugally Lift Off Sprags Freewheels

RDBK RDBK-H



TYPE



The type RDBK is a centrifugally lift-off sprag RSCI high speed backstop (Please refer to pages 74 to 77) equipped with integral torque limiter. The latter limits the backstop transmissible torque to a value that is factory set-up according to customer request.

This design will be used mostly as backstop in multi-drive systems, such as on large inclined conveyors, where two or more backstops share the reverse load.

The torque limiting function is performed through a multi-disc brake working in oil. This solution provides not only for a high torque density of the complete unit, but also insures that the set slip torque remains constant over the working life time regardless of the environmental conditions.

The RDBK sub-assembly which rotate backwards under overload is fully bearing supported. The unit is

capable of performing as many reverse rotations as may be required (within the limits of energy dissipation) to completely unload the conveyor prior to maintenance work being carried out. Within some time intervals this type can rotate regularly backwards damage free.

The option of a release function manually actuated is also available. A hydraulic solution is the preferred one, nevertheless a full mechanical one can be supplied. The release is performed using a simple hand pump to actuate the internal hydraulic cylinder; progressively releasing the backstop.

The backstop function is of the built-in design. The outer part must be centered and fixed on the machine housing. The run-out and squareness tolerances must be respected.

Centrifugally Lift Off Sprags Freewheels

RDBK, RDBK-H

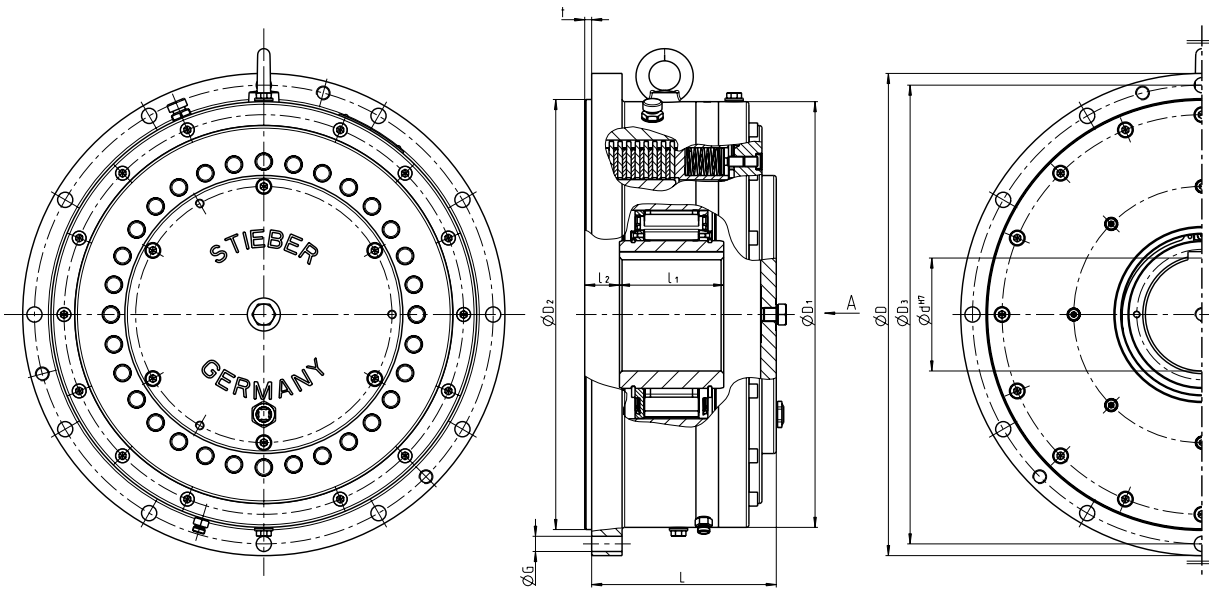

Type	Size														Number	G	Weight
		$d_{H7\max}$ [mm]	$T^1)$ [Nm]	$n_{\min}^{2)}$ [min ⁻¹]	$n_{\max}^{3)}$ [min ⁻¹]	$n_{r\max}^{4)}$ [min ⁻¹]	D	D ₁	D ₂₉₇	D ₃	t	L	I ₁	I ₂ ⁵⁾			
RDBK RDBK..H	125-63	60	5500	360	6000	270	330	285	280	308	6	158	90	29	6	M12	65
	180-58	100	12500	290	3000	220	430	375	375	403	6	170	80	31	6	M12	115
	210-63	130	19000	270	2400	205	500	438	425	473	6	190	90	40	6	M16	170
	240-83	130	30000	260	2400	195	555	490	495	528	8	215	120	40	12	M16	250
	280-83	150	40000	235	2000	175	660	580	580	620	8	230	120	40	12	M20	380
	280-96	150	50000	220	2000	165	660	580	580	620	8	230	120	40	12	M20	380
	310-83	180	60000	220	1300	165	710	630	630	670	8	235	120	50	12	M20	450
	310-96	180	70000	210	1300	160	710	630	630	670	8	235	120	50	12	M20	450
	360-83	230	82000	200	1100	150	780	700	700	740	8	245	120	50	16	M20	570
	360-96	230	102000	190	1100	145	780	700	700	740	8	245	120	50	16	M20	570
	460-96	300	180000	170	1000	130	975	870	850	925	10	275	120	63	16	M30	950

NOTES

- Maximal slipping torque.
A lower slipping torque can be set.
- This minimum allowable overrunning speed n_{\min} should not be reduced under continuous operation. Possible reduction of this minimum speed on request.
- Maximal speed, inner race overruns
Keyway to DIN 6885.1
- Maximum speed rolling backwards,
internal brake open
- Tolerance +2

When ordering, please specify direction of rotating seen from arrow »A«.

- »R« Inner race overruns in clockwise direction.
- »L« Inner race overruns in counterclockwise direction.

» Refer to mounting and maintenance instructions pages 12 to 13

MOUNTING EXAMPLE

